

UW-14

Bathroom call module

Nurse Call
System

udeCOM

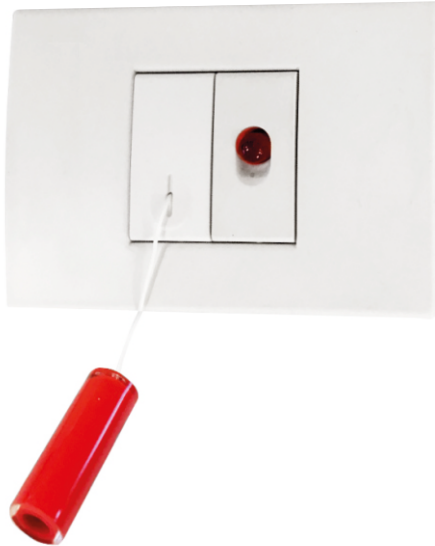

The UW-14 allows making a call in the bathroom / WC area.

A pull cord of 1.6 meters long will activate a flashing red light in the corridor and led activity indicator in the UW-14 module. Also the central station (UC-102) will receive a bathroom / WC call.

The bathroom call module activity can only be cancelled via room substation (UC-104) presence.

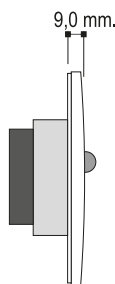
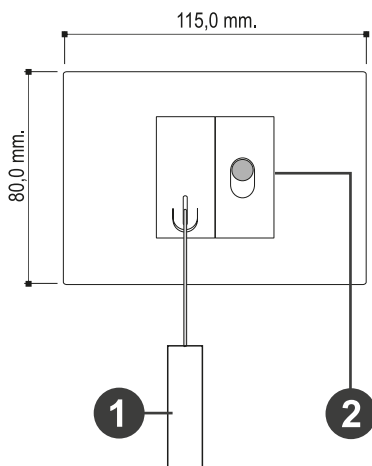

- 1 Call drawer
- 2 Bathroom call indicator

Mounting accessories

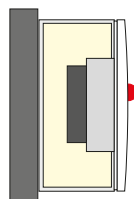

UW-84

SURFACE
BACK BOX

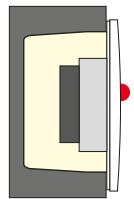

UW-94

FLUSH MOUNTED
BACK BOX FOR
SOLID WALL

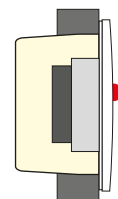

UW-74

FLUSH MOUNTED
BACK BOX FOR
CAVITY WALL



EQUIPOS Y SISTEMAS MEGAFONÍA / INTERCOM • PUBLIC ADDRESS SYSTEMS

UNIÓN DESARROLLOS ELECTRÓNICOS

Tel.: +34 934 772 854 / +34 609 914 787 • ude@udeaudio.com • BARCELONA - SPAIN

www.udeaudio.com

rev.1 | 610.414A | 1 / 1

Connection diagram

INDEPENDENT BATHROOM SUBSTATION (UC-104)

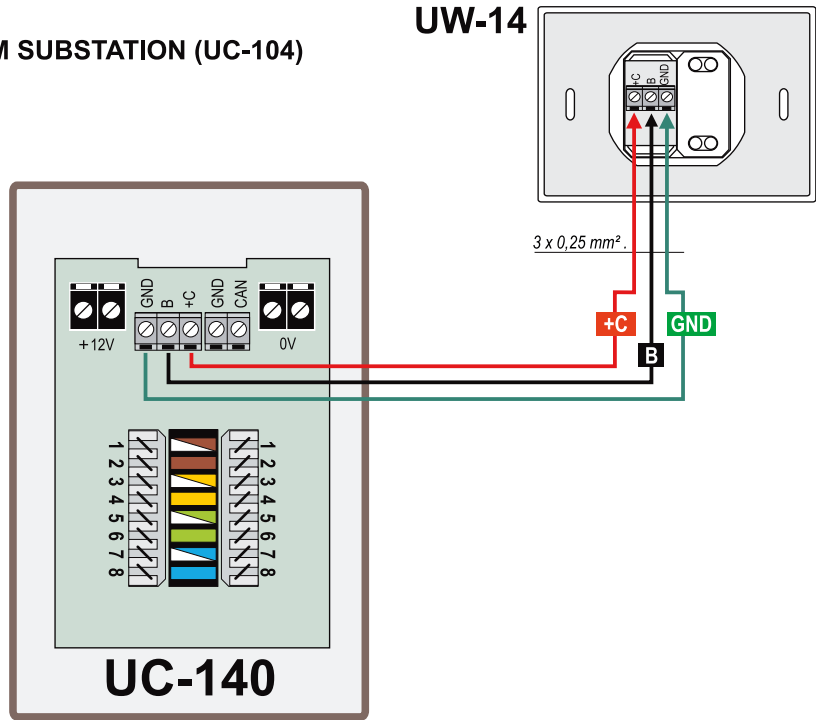

ROOM SUBSTATION CONNECTION (UC-104)

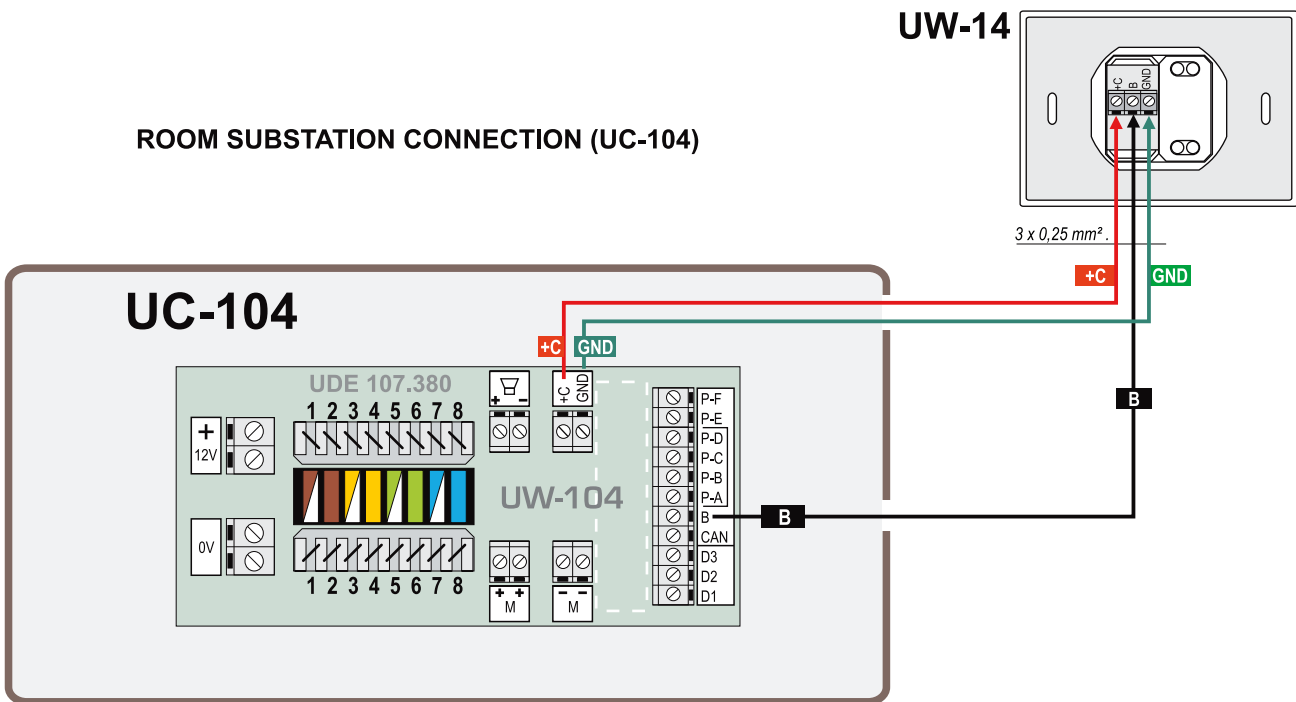

NOTE:
 Bathroom call module (UW-14) has to be installed according to regulations (MIE BT 024) or according to equivalent norms in the country of destination